

1. General Description

The ADD1021 is a Power Line Communications System on Chip, which implements a full PRIME compliant PLC modem. It includes an enhanced 8051 microcontroller (IP core ADD8051C3A), a Medium Access Controller (MAC) (IP core ADD1221) and a Modem circuit (IP core 1321) for power line medium using OFDM modulation compatible with PRIME specifications.

ADD1021 is oriented to high performance & robust AMR systems. The SoC is designed to be used by meter manufacturers to provide a low cost and compact solution for AMR & AMM systems using narrow band power line communications.

This device has been developed to reduce CPU computational load in PLC systems running PRIME protocols. ADD1021 includes all necessary resources to be used as main controller in metering applications, and allows an external device to communicate according to PLC PRIME specifications.

Features:

- Power Line Carrier Modem for 50 and 60Hz mains
- 97-carriers OFDM PRIME compliant
- Baudrate: 21400 to 128600 bps
- Differential BPSK, QPSK, 8-PSK PRIME compliant modulations
- Viterbi decoding and CRC PRIME compliant
- Enhanced 8051 core, Average speedup of 5 times
- 32Kbytes On-Chip SRAM
- Up to 256Kbytes external SRAM
- AES encryption PRIME compliant
- Automatic Gain Control and signal amplitude tracking
- Embedded On-chip DMA's
- Auto Boot-loading program from Serial Flash
- Code encryption in bootloading
- In-circuit Serial Flash Programming
- Programmable watchdog
- 2xUART
- Buffered SPI to external metering IC
- Power Supply 3.3v
- Pb-Free and RoHS compliant
- Ambient Temperature Range: -40°C to +85°C

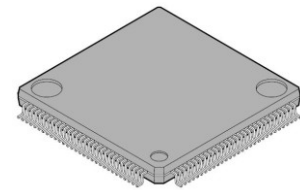

120-pin plastic LQFP
(14 x 14mm)

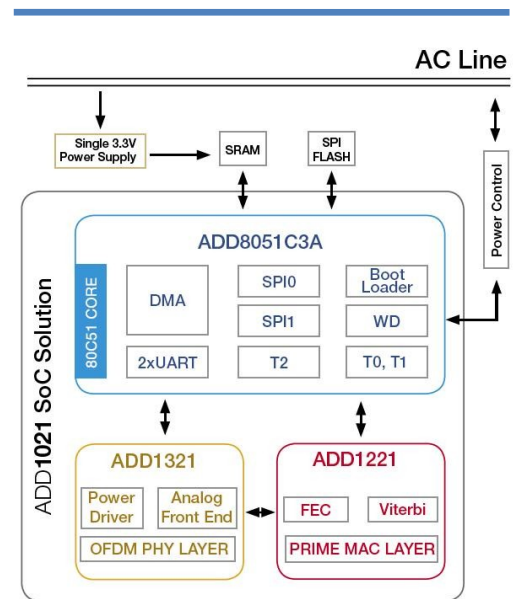

MARKING DIAGRAM

ADD	=Customer Logo
ADD1021AQF120	=Customer Part number
00000	=Country of Origin
YYWW	=Year/week code
TTT	=Control Code
LL	=Lead Free Code

Ordering Code : **ADD1021AQF120**
Pb-Free

1.1 Block Diagram

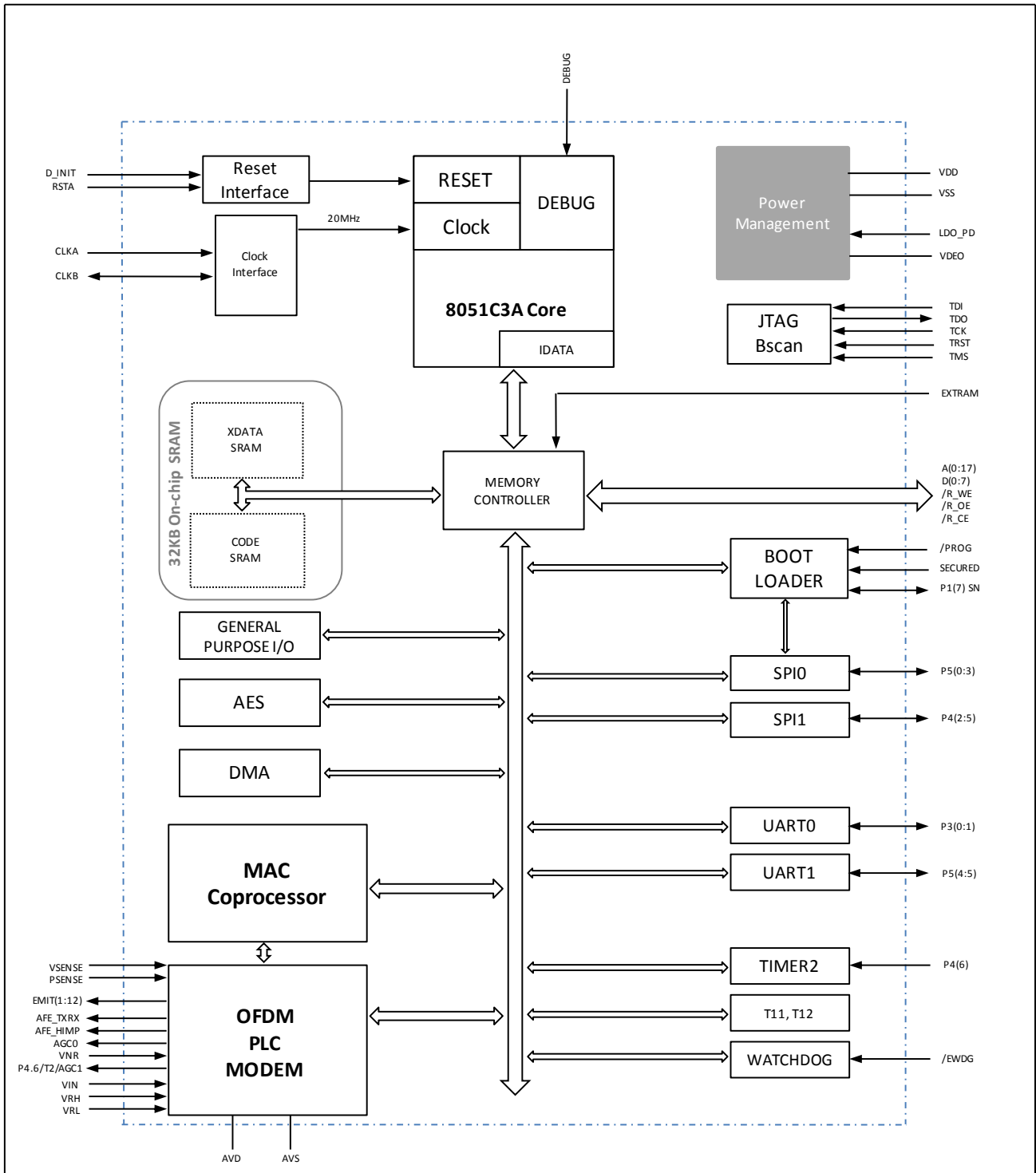

Figure 1. ADD1021 Block Diagram

2. Mechanical data

120-pin plastic LQFP (14x14mm) Pb-free, RoHS compliant.

Ambient Temperature Range: -40°C to +85°C.

Ordering Code: **ADD1021AQF120**

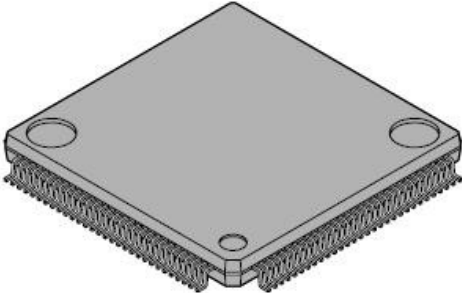
<p style="text-align: center;">120-pin plastic LQFP</p>  <p style="text-align: center;">(FPT-120P-M24)</p>	Lead pitch	0.40 mm
	Package width × package length	14.0 mm × 14.0 mm
	Lead shape	Gullwing
	Sealing method	Plastic mold
	Mounting height	1.70 mm MAX
	Code (Reference)	P-LFQFP120-14×14-0.40

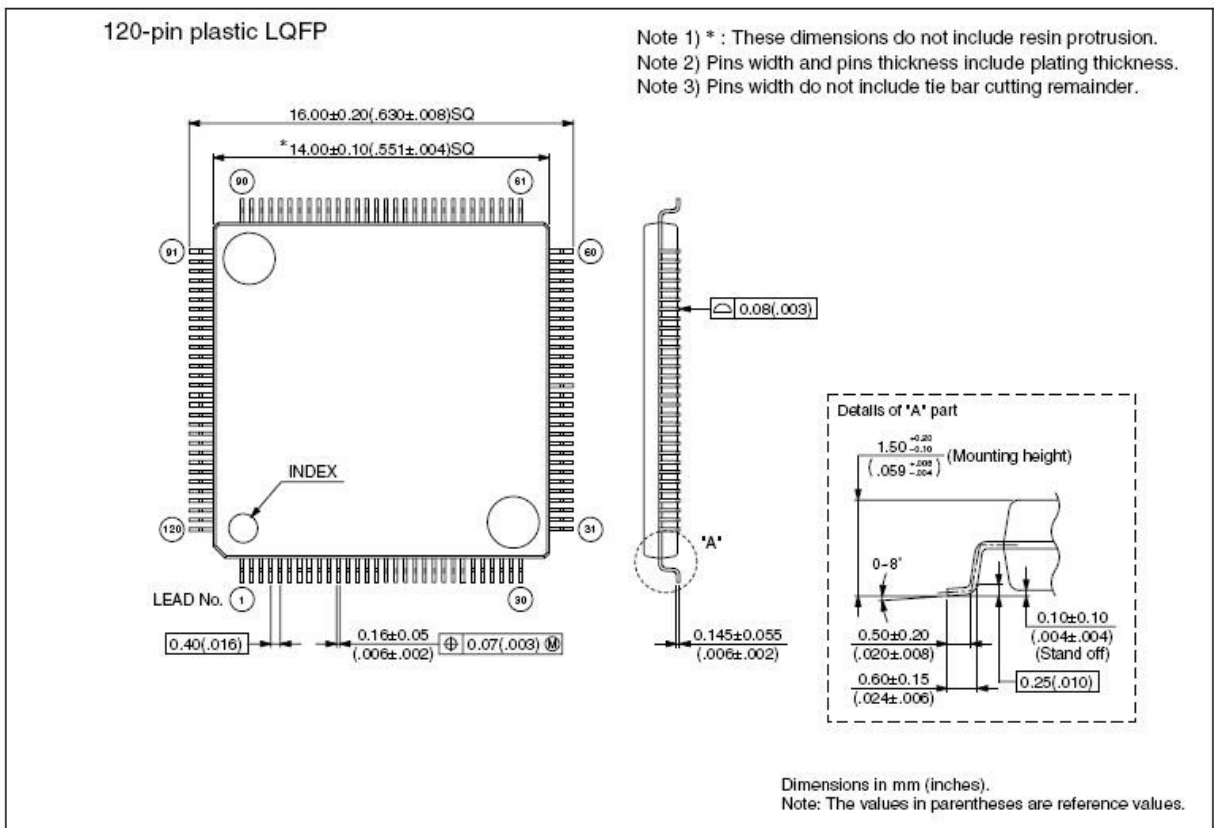

2.1 Recommended mounting conditions

2.1.1 Conditions of Standard Reflow

Items	Contents	
Method	IR(Infrared Reflow) / Convection	
Times	2	
Floor life	Before unpacking	Please use within 2 years after production
	From unpacking to second reflow	Within 8 days
	In case over period of floor life	Baking with 125°C +/- 3°C for 24hrs +2hrs/-0hrs is required. Then please use within 8 days. (please remember baking is up to 2 times)
Floor life condition	Between 5°C and 30°C and also below 70%RH required. (it is preferred lower humidity in the required temp range.)	

Temperature Profile

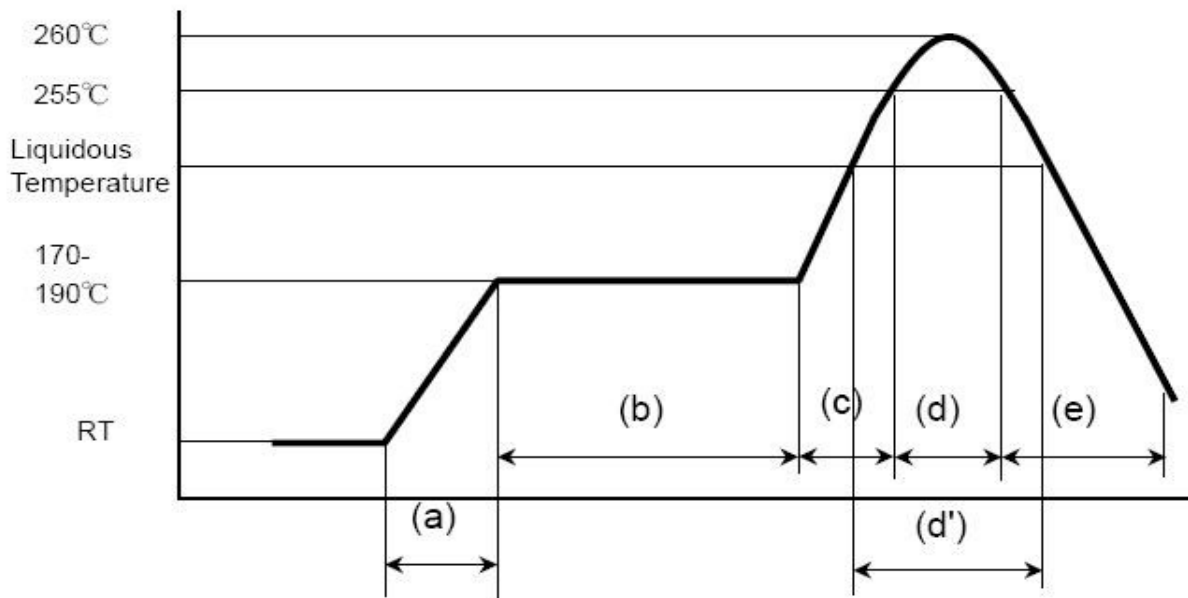

H rank: 260°C Max

(a) Average ramp-up rate: 1°C/s to 4°C/s

(b) Preheat & Soak: 170°C to 190°C, 60s to 180s

(c) Average ramp-un rate: 1°C/s to 4°C/s

(d) Peak temperature: 260°C Max, Up to 255°C within 10s

(d') Liquidous temperature: Up to 230°C within 40s or
 Up to 225°C within 60s or
 Up to 220°C within 80s

(e) Cooling: Natural cooling or forced cooling

**Temperature on the top of the package is measured*

2.1.2 Manual Soldering

Items	Contents	
Floor life	Before unpacking	Please use within 2 years after production
	From unpacking to Manual Soldering	Within 2 years after production (No control required for moisture adsorption because it is partial heating)
Floor life condition	Between 5°C and 30°C and also below 70%RH required. (It is preferred lower humidity in the required temp range.)	
Solder Condition	Temperature of soldering iron: Max 400°C, Time: Within 5 seconds/pin *Be careful for touching package body with iron	